



TROJAN **UV**3000™ PTP



**Trojan Technologies**

## Trojan UV3000™PTP

Technology you can trust from the industry leader

Trojan Technologies Inc. is an ISO 9001 registered company and for more than 25 years has set the standard for proven UV technology and ongoing innovation. With unmatched scientific and technical expertise, and a global network of specialists, representatives and technicians, Trojan is trusted more than any other firm as the best choice for municipal UV solutions – worldwide.

The Trojan UV3000™PTP (Packaged Treatment Plant) is one of the reasons why. First introduced in 1991, it is an enhancement to the very successful UV2000, which pioneered ultraviolet disinfection in wastewater plants with the first-ever open channel design. Over the past decade, the UV3000™PTP has become recognized as the standard for UV system design. Today, there are more than 3,000 Trojan UV Municipal systems installed worldwide. The UV3000™PTP is ideally suited for wastewater disinfection applications up to 1.4 MGD.



# TROJAN UV3000™ PTP

An 'off-the-shelf' solution designed for economical disinfection



### System Monitor

The optional system monitor includes a submersible sensor that monitors lamp hours and UV intensity at each bank. Elapsed time display provides continuous readout of actual hours of operation. Display is visible through the panel door. A dry contact enables a remote low UV intensity alarm.



### Electronic Ballast

The electronic ballast is mounted within its own Type 4 (IP65)-rated watertight enclosure within the module frame.



### Power Distribution Receptacles (PDRs)

Each optional PDR powers 2 UV modules and allows for quick and safe electrical disconnect. Ground fault protected for operator safety. The duplex ground fault interrupter receptacles are mounted inside Type 3R rain shield boxes.



### Fixed Weir

Maintains the correct channel effluent depth over different flow rates, with maximum height of 1.5 inches (3.8 cm) of effluent at peak flow. Equipped with a drain for easy channel cleaning. Weirs are used with concrete channel and stainless steel channel option.



### UV Modules

UV lamps are mounted on modules installed in open channels. The lamps are enclosed in quartz sleeves, and positioned horizontally and parallel to water flow. A bank is made up of multiple modules placed in parallel positions. All ballast, lamp and sensor wiring runs inside the module frame.

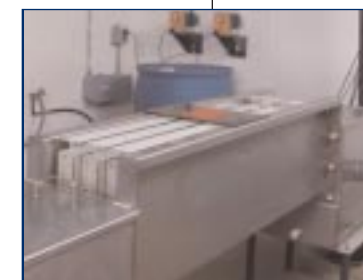

### Effluent Channel

An optional Type 304 stainless steel channel, complete with UV Module Support Rack, can be used. Channel can be set into a poured concrete channel or installed as a freestanding structure connected to flanged pipes using the optional transition boxes. Gravity flow eliminates need for pumps, pipe valves or fittings.



### Transition Boxes

The optional transition boxes are positioned at the channel's inlet and outlet points to create a plug flow condition throughout the UV system. This enhances disinfection efficiency. Boxes feature hinged, stainless steel lids with handles for easy access and drain plugs for ease of cleaning. For stainless steel channels only.

## Key Benefits of the TrojanUV3000™PTP

- **Cost-effective disinfection solution** due to its simple, easy-to-maintain design.
- **Bioassay validated dose delivery provides peace of mind.** Trojan's bioassay testing demonstrates the system's disinfection performance in real-world conditions; you don't have to rely on theoretical calculations.
- **Reduced installation costs.** The entire UV3000™PTP can be quickly and inexpensively installed into existing channels or chlorine contact basins.
- **Reduced capital costs.** The complete UV3000™PTP system can be installed outdoors, eliminating the need and capital costs of a building, shelter or air conditioning.
- **Reduced space requirements** since ballasts are housed within the module instead of in external cabinets, resulting in a smaller footprint.
- **Reduced operating costs.** Gravity-fed design eliminates costs of pressurized vessels, piping and pumps.
- **Enhanced component performance.** UV Modules are constructed of Type 316 stainless steel with excellent corrosion resistance to cleaning solutions.
- **Easy expansion as your needs grow** thanks to its modular design.
- **Reduced maintenance requirements** due to design features like triple seal lamp-sockets which protect against moisture entry and algae growth within channel and transition connections.
- **Easy cleaning.** Modules are electrically separated from each other, allowing for one module to be removed for cleaning or repair. A spare module can quickly be inserted to maintain maximum performance.
- **Increased operator safety and no disinfection by-products.** Trojan's UV3000™PTP uses environmentally safe ultraviolet light – not chlorine.
- **Comprehensive warranty protection** for your investment.

# Open-Channel Architecture Designed for Outdoor Installation

Cost-effective to install and expand

## Benefits:

- **Compact, open channel design allows cost-effective installation in existing effluent channels and chlorine tank basins**
- **Gravity-fed design eliminates costs of pressurized vessels, piping and pumps**
- **System can be installed outdoors to reduce capital costs – no building, shelter or air conditioning is required**
- **Open channel allows for easier cleaning and maintenance**
- Redundancy requirements are minimized by allowing disinfection to continue while performing maintenance on UV modules and channel
- The system offers a true off-the-shelf solution for operators with restricted budgets and basic disinfection requirements



*The Trojan UV3000™PTP system delivers flexibility and cost savings through its simple installation in existing channels and chlorine contact tanks. The system is completely stand-alone and can be situated outdoors with no additional building, shelter or cooling requirements.*

# Modular Design Simplifies System Expansion

Provides maximum flexibility for changing needs

## Benefits:

- **Trojan's modular approach is the building block for maximum flexibility and efficiency**
- **The number of modules can be easily increased to suit different flowrates and disinfection needs**
- **Modular design is readily expandable to meet new regulatory or capacity requirements**
- Trojan's design approach ensures effluent quality, upstream treatment processes, and O&M needs are addressed in system configuration
- Horizontal lamp mounting delivers optimal hydraulic performance. This induces turbulence and dispersion and maximizes wastewater exposure to UV output.

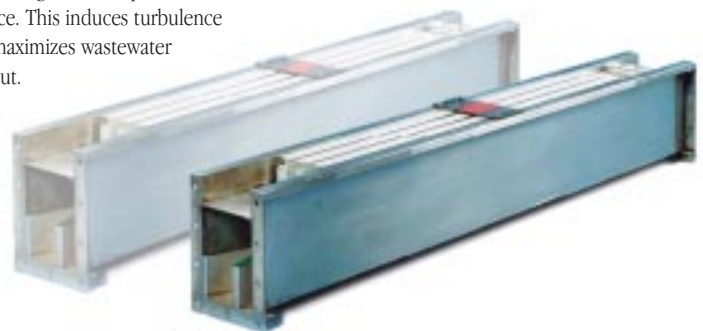

# Advanced, Self-Contained UV Module

Dramatically reduces footprint size and eliminates costs of air conditioning

## Benefits:

- Lamps are protected in a fully-submersible, Type 316 stainless steel frame
- Waterproof module frame protects cables from effluent and UV light
- Space-saving electronic ballasts are housed right in the module, not separate external cabinets, to minimize footprint size, and installation time and costs



*All wiring and cables are safely enclosed inside the waterproof module frame.*

- The electronic ballast is mounted within its own Type 4 (IP65)-rated airtight enclosure within the module frame
- Convection cooling of the ballast eliminates cost associated with air conditioning or forced-air cooling

- Modules are electrically separated from each other, allowing for one module to be removed for maintenance. A spare module can quickly be inserted to maintain maximum performance.
- Streamlined module minimizes head loss and prevents build-up of debris
- All module wiring is pre-installed and factory-tested

## Trojan's Innovative Ballasts and Enclosures Provide Significant Advantages

Trojan UV3000™PTP ballasts are housed within the module, rather than in external cabinets	<ul style="list-style-type: none"> <li>• This takes up less space and footprint, reducing installation time and costs</li> </ul>
Trojan UV3000™PTP utilizes convection cooling	<ul style="list-style-type: none"> <li>• Housing the ballasts in the module allows for convection cooling to dissipate the heat of the ballasts into the air</li> <li>• The ballasts are kept sealed and protected</li> <li>• No air conditioning or forced-air cooling required</li> </ul>
Trojan UV3000™PTP ballast enclosure provides a clean, protected environment	<ul style="list-style-type: none"> <li>• Some suppliers use external cabinets, with forced-air cooling. This introduces dust and moisture onto circuit boards and other electronic components greatly reducing the life of these components</li> <li>• By housing the module internally the components remain dry and clean</li> </ul>
Trojan UV3000™PTP utilizes internal cabling	<ul style="list-style-type: none"> <li>• All lamp-ballast wiring is contained within the module frame. This configuration protects wires and cables from exposure to effluent and UV light</li> <li>• Internal cabling allows all electrical connections within the module to be factory tested</li> </ul>

## High Efficiency Electronic Ballasts

Conserve energy and prolong lamp life

### Benefits:

- **Electronic ballasts are more compact, generate less heat, and are more efficient than electromagnetic ballasts**
- **In a multi-unit system, banks of UV lamps can be turned off manually to conserve energy when flow rates are minimal**
- Ballasts operate on standard 120V A/C, minimizing electrical requirements and installation costs



*Trojan's electronic ballasts generate less heat and are more compact than electromagnetic ballasts.*

## Designed for Easy Maintenance

Simplicity of design allows for fast cleaning and upkeep

- Lamps are available from more than one source, and are easily replaced without tools. One lamp can be replaced in 3-5 minutes on average
- Trojan lamps are guaranteed for 12,000 hours of operation
- 1 module can be unplugged and removed without disrupting flow or system performance

### Cleaning Options

- Maintenance Rack – a mobile, stainless steel rack holds 1 UV module. Allows operator to clean and change lamps as required.



*Trojan's mobile stainless steel rack allows for fast cleaning and quick lamp replacement.*

# EPA-Endorsed Bioassay Validated Performance

Real-world testing ensures accurate dose delivery

## Benefits:

- Performance data is generated from real-world testing over a range of flows, effluent quality, and UVTs
- Provides physical verification that system will perform as expected; ensures public and environmental safety
- Provides accurate assessment of equipment sizing needs

- The Trojan UV3000™PTP has been thoroughly validated through real-world bioassay testing under a wide range of operating conditions
- Real-world bioassay testing offers the peace of mind and improved public and environmental safety of verified dose delivery, not theoretical calculations

## Basing System Design on Theoretical Dose Calculations Can Result In Undersizing of Equipment and Underdosing

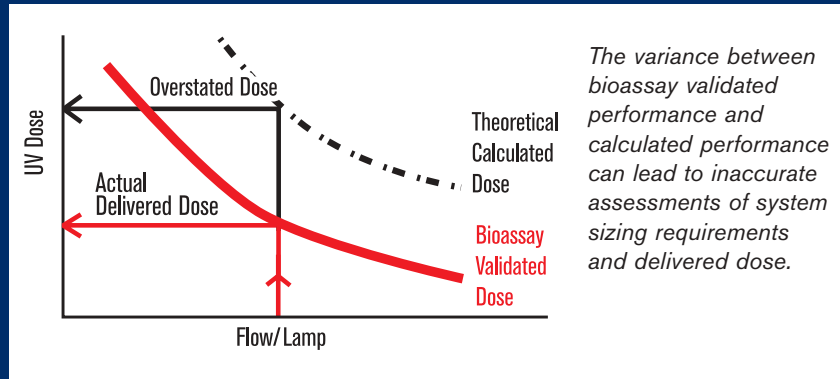

- The U.S. Environmental Protection Agency (EPA) has endorsed bioassays as the standard for assessment and comparison of UV technologies
- The disinfection performance ratings for the Trojan UV3000™PTP are proof that what you see is what you actually get

# Stainless Steel Channels and Transition Boxes

Faster, easier and less expensive to install versus concrete

## Benefits

- **Stainless steel is easier to work with, especially on small projects**
- **It takes less time to install stainless steel channels**

- The UV3000™PTP channel is constructed from Type 304 stainless steel and comes complete with UV module support rack and downstream serpentine weir
- Stainless steel transition boxes at the UV channel's inlet and outlet points permit connection to flanged pipes
- The transition box connections enhance disinfection efficiency by creating a plug flow condition throughout the UV system



Trojan's stainless steel transition box enhances disinfection efficiency and is easily connected to flanged pipes.

## System Specifications

Model #	Typical Peak Flows		Rated Power Requirements (Watts)	Approximate Dimensions for reference value only (inches / cm)									
	US gal/day x 1000	cu m/hr		L <sub>1</sub>	L <sub>2</sub>	H <sub>1</sub>	H <sub>2</sub>	H <sub>3</sub>	H <sub>4</sub>	W <sub>1</sub>	W <sub>2</sub>	W <sub>0</sub>	E DIA
3025K-PTP	40	6	90	48 / 122	84 / 213	15 / 38	19 / 48	5.5 / 14	9 / 23	3 / 8	9 / 23	5-6.5 / 13-16	4 / 10
3050K-PTP	80	13	180	48 / 122	84 / 213	15 / 38	19 / 48	5.5 / 14	9 / 23	6 / 15	12 / 30	5-6.5 / 13-16	6 / 15
3075K-PTP	120	19	270	48 / 122	84 / 213	15 / 38	19 / 48	5.5 / 14	9 / 23	9 / 23	14 / 36	5-6.5 / 13-16	6 / 15
3100K-PTP	140	22	350	96 / 244	132 / 335	15 / 38	22 / 56	8 / 20	12 / 30	6 / 15	14 / 36	5-6.5 / 13-16	8 / 20
3150K-PTP	210	33	525	96 / 244	132 / 335	15 / 38	22 / 56	8 / 20	12 / 30	9 / 23	15 / 38	5-6.5 / 13-16	8 / 20
3200K-PTP	280	44	700	96 / 244	132 / 335	15 / 38	22 / 56	8 / 20	12 / 30	12 / 30	16 / 41	5-6.5 / 13-16	8 / 20
3250K-PTP	350	55	875	96 / 244	132 / 335	15 / 38	22 / 56	9 / 23	13 / 33	15 / 38	19 / 48	5-6.5 / 13-16	10 / 25
3300K-PTP	420	66	1050	96 / 244	132 / 335	15 / 38	22 / 56	9 / 23	13 / 33	18 / 46	22 / 56	5-6.5 / 13-16	10 / 25
3350K-PTP	490	77	1225	96 / 244	132 / 335	15 / 38	22 / 56	9 / 23	13 / 33	21 / 53	25 / 64	5-6.5 / 13-16	10 / 25
3400K-PTP	560	88	1400	115 / 292	163 / 414	21 / 53	33.5 / 85	10 / 25	16.5 / 42	12 / 30	19 / 48	11-12.5 / 28-32	12 / 30
3500K-PTP	700	110	1750	115 / 292	163 / 414	21 / 53	33.5 / 85	10 / 25	16.5 / 42	15 / 38	19 / 48	11-12.5 / 28-32	12 / 30
3600K-PTP	840	133	2100	115 / 292	163 / 414	21 / 53	33.5 / 85	10 / 25	16.5 / 42	18 / 46	22 / 56	11-12.5 / 28-32	12 / 30
3700K-PTP	980	155	2450	115 / 292	163 / 414	21 / 53	33.5 / 85	10 / 25	16.5 / 42	21 / 53	25 / 64	11-12.5 / 28-32	12 / 30
3800K-PTP	1120	177	2800	115 / 292	163 / 414	21 / 53	33.5 / 85	10 / 25	16.5 / 42	24 / 61	28 / 71	11-12.5 / 28-32	12 / 30
3900K-PTP	1260	199	3150	115 / 292	163 / 414	21 / 53	33.5 / 85	10 / 25	16.5 / 42	27 / 69	31 / 79	11-12.5 / 28-32	12 / 30
3001M-PTP	1400	221	3500	115 / 292	163 / 414	21 / 53	33.5 / 85	10 / 25	16.5 / 42	30 / 76	34 / 86	11-12.5 / 28-32	12 / 30

\* Please consult factory for dimensions applicable to a poured concrete channel and for exact dimensions of stainless steel channels.

## Recommended Spare Parts

To facilitate easy and timely maintenance, it is recommended that the following equipment be ordered at the time of system purchase:

- 4 lamps
- 4 sleeves
- 4 lamp holders (seal socket assemblies)

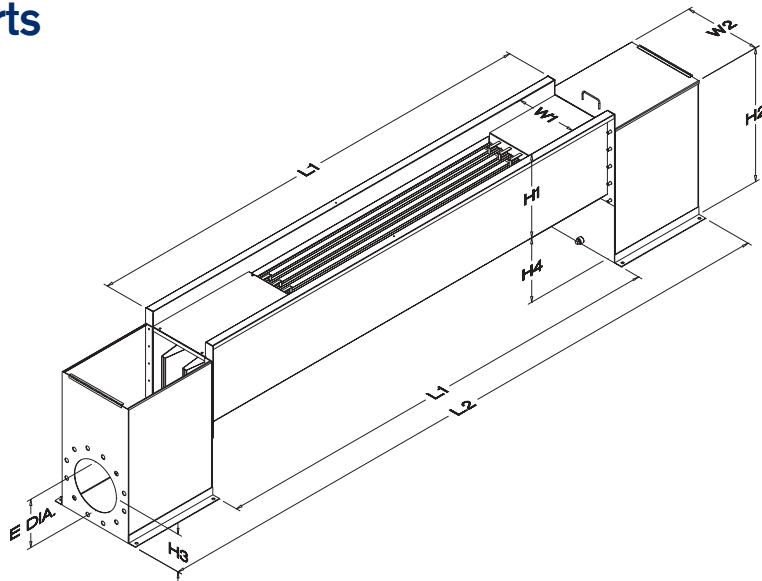

Find out how your wastewater treatment plant can benefit from Trojan UV3000™PTP – call us today.



**Trojan Technologies Inc.**

Head Office (Canada)  
3020 Gore Road  
London, Ontario  
Canada N5V 4T7  
Telephone: (519) 457-3400  
Fax: (519) 457-3030

[www.trojanuv.com](http://www.trojanuv.com)

Trojan Technologies is a publicly traded company on the Toronto Stock Exchange under the symbol TUV.

Products in this brochure may be covered by one or more of the following patents:  
CA 1,327,877 US 4,872,980  
US 5,006,244  
Other Patents pending.

Printed in Canada. ©2002 Trojan Technologies Inc., London, Ontario, Canada.  
No part of this publication may be reproduced, stored in a retrieval system, or transmitted in any form or by any means without the written permission of Trojan Technologies Inc.  
0A-W-M&S-5.2-BR-CA0005-0902